

Distribution Agreement

In presenting this thesis or dissertation as a partial fulfillment of the requirements for an advanced degree from Emory University, I hereby grant to Emory University and its agents the non-exclusive license to archive, make accessible, and display my thesis or dissertation in whole or in part in all forms of media, now or hereafter known, including display on the world wide web. I understand that I may select some access restrictions as part of the online submission of this thesis or dissertation. I retain all ownership rights to the copyright of the thesis or dissertation. I also retain the right to use in future works (such as articles or books) all or part of this thesis or dissertation.

Signature:

Julianna E. Bozler

Date

Genetic Basis for DDT resistance associated with Cyp6g1 in *Drosophila simulans*

By

Julianna Elizabeth Bozler
MPH

Department of Environmental Health

Gary W. Miller, PhD
Committee Chair

Paige Tolbert, PhD
Committee Member

Todd Schlenke, PhD
Committee Member

Genetic Basis for DDT resistance associated with Cyp6g1 in *Drosophila simulans*

By

Julianna Elizabeth Bozler

Bachelors of Science
Arizona State University
2010

Thesis Committee Chair: Gary W. Miller, PhD

An abstract of
A thesis submitted to the Faculty of the
Rollins School of Public Health of Emory University
in partial fulfillment of the requirements for the degree of
Masters of Public Health
in Environmental Health
2013

Abstract

Genetic Basis for DDT resistance associated with Cyp6g1 in *Drosophila simulans*

By Julianna E. Bozler

Insecticide resistance is an important example of anthropogenic driven evolution: With the wide spread use of insecticides we have experienced the rapid development of resistant phenotypes in many insect species. This is a recurrent reality encountered by many public health initiatives, including those undertaken to control malaria. Moving forward, a thorough understanding of the mechanisms of resistance will be essential to generating the next generation of insecticides. In effort to elucidate the molecular and evolutionary mechanisms behind insecticide resistance, researchers have turned to non-target species, such as *Drosophila melanogaster*, which have demonstrated significant field resistances to pesticides such as DDT. One classic example of such a mutation is the Accord transposon inserted in the 5' regulatory region of the DDT-resistance gene CYP6g1 of *Drosophila melanogaster*. This mutation is associated with constitutive Cyp6g1 over-expression and insecticide resistance. A similar mutation was found in *Drosophila simulans*, whereby a Doc transposable element inserted in the 5' regulatory region of Cyp6g1 also associated with increased Cyp6g1 expression and insecticide resistance. We have made several reporter constructs to identify the specific Doc gene sequences necessary for Cyp6g1 over-expression. Furthermore, to better understand the functional consequences of the *D. simulans* Cyp6g1 Doc insertion, we have characterized the tissue-specific expression pattern of CYP6g1 in Doc+ and Doc- strains. These findings may contribute to a larger understanding of the mechanism of resistance in insect species.

Genetic Basis for DDT resistance associated with Cyp6g1 in *Drosophila simulans*

By

Julianna Elizabeth Bozler

Bachelors of Science
Arizona State University
2010

Thesis Committee Chair: Gary W. Miller, PhD

A thesis submitted to the Faculty of the
Rollins School of Public Health of Emory University
in partial fulfillment of the requirements for the degree of
Masters of Public Health
in Environmental Health
2013

Acknowledgements

I would like to acknowledge the contributions of Dr. Nathan Mortimer; for guidance and input on the research that contributed to this thesis. I would also like to recognize Balint Kacsoh and the other members of the Schlenke Lab as well as the students, faculty, and staff of Emory's School of Public Health.

Table of Contents

Introduction	1
Methods	7
Results	10
Discussion	13
Figures and Tables:	
Figure 1: Location of the Doc transposon insertion in DDT-resistant <i>D. simulans</i>	18
Figure 2: Fractional Survival of adult Sim6(Doc+) and Sz3(Doc-) across DDT concentrations.	19
Figure 3: Transcript length of <i>Cyp6g1</i> in Sim6 (Doc+) and Sz3 (Doc-).	20
Figure 4: Reporter constructs for characterization of <i>Cyp6g1</i> expression.	21
Figure 5: Tissue specific expression of reporter driven by 6g1promoter and Doc+6g1promoter in 3 rd instar larvae.	22
Figure 6: Tissue specific expression of reporter driven by 6g1promoter and Doc+6g1promoter in adult transgenics.	23
Figure 7: Tissue specific expression of <i>Cyp6g1</i> in Sim6 (Doc+) and Sz3 (Doc-) 3 rd instar larvae.	24
Figure 8: Tissue specific expression of <i>Cyp6g1</i> in Sim6 (Doc+) and Sz3 (Doc-) adults.	25
Figure 9: Tissue specific expression of DocHsp70 in 3 rd instar larvae.	27
Figure 10: Tissue specific expression driven by DocHsp70 in adults.	28
Table 1: Relative quantification of tissue specific <i>Cyp6g1</i> expression compared to RP49 in Sim6 (Doc+) and Sz3 (Doc-).	26
References	29

Introduction

Insecticide resistance is an important example of anthropogenic driven evolution: With the wide spread use of insecticides we have experienced the rapid development of resistant phenotypes in many insect species: 500 arthropod species are reported to have insecticide resistance, many of which have been identified as important to public health (Rex Consortium 2013). The rise and persistence of such resistance has broad implications, threatening food crop productivity and reducing the efficacy of vector control for disease management.

By convention we understand that the greater the use of a pesticide, the stronger selective pressure there is on insect species to adapt. Until recently however, the speed at which mutations were able to arise and fix in populations had not been fully appreciated. A classic example of this is dichlorodiphenyltrichloroethane (DDT), one of the first insecticides used on a global scale. DDT was developed in 1939, and the first documented instance of DDT resistance occurred less than a decade later, in 1946 (Denholm 2002). Since its initial introduction into the market, instances of DDT resistance have continued to increase in frequency in both target and non-target insect species (Bridges 2012, Wyckhuys 2013, Denholm 2002). Many Mosquito populations throughout the world now exhibit increased tolerance or resistance to DDT, which is particularly problematic in malaria prone regions (Cohen 2012).

A common approach to managing this reality is openly engaging in an arms race of sorts; relying on the development of new insecticides and turning to novel innovations in genetically modified food, such as Bt corn, for crop protection (Devos

2013). However, such alternatives are not available in all situations, particularly in vector control (Kuntworbe 2012).

DDT and the Fight Against Malaria

Malaria is an insect-borne disease, responsible for more than half of a million deaths in 2010 (WHO 2013). It is one of the most devastating vector-borne diseases, impacting more than 200 million people world wide, and is therefore a principal public health concern (WHO 2010, WHO 2013). Malaria is caused by four species of protozoa belonging to the genus *Plasmodium*: However, transmission of the disease is dependent on *Anopheles* mosquitoes as vectors (Kuntworbe 2012). This complex transmission cycle of vector-borne parasites requires specialized disease-control programs.

The control of vector-borne diseases typically relies on a multifaceted approach, coordinating disease treatment with prevention and monitoring programs. Comprehensive efforts utilizing antibiotics, vaccines, vector control, and other public health initiatives can successfully restrict the impact of a disease; unfortunately, not all of these resources are available to combat malaria. Currently, a practical malaria vaccine is not available, and malaria parasites continue to develop resistance to drugs capable of treating the disease (Lo 2013).

These limitations have led to a great reliance on vector control measures as a means of disease management (Bridges 2012, Kuntworbe 2012). Although new techniques have been developed for this purpose, such as the introduction of sterile males

into breeding populations, the primary method of vector control remains the application of pesticides (WHO 2010, Rex Consortium 2013).

Effective malaria control in many areas has relied heavily on DDT, both environmental application and indoor residual spraying, where it functions as an insecticide and insect repellent (WHO 2013, van den Berg 2012). Despite the many advances in the field, indoor residual spraying (IRS) of DDT remains one of the most effective and inexpensive control measures (WHO 2010). Unfortunately, DDT resistance is a globally observed phenomenon, and high frequencies of DDT resistance within mosquito populations has been shown to reduce the efficacy of IRS treatment (Cohen 2012).

Resistance to DDT in malaria vector populations has continued to spread; three of the main vectors in Africa, *Anopheles gambiae s.s.*, *A. gambiae s.l.*, and *A. arabiensis* have tested positive for DDT resistance in recent years (Nwane 2013, Edi 2012). In Asia, India is similarly afflicted with DDT resistance in their vector populations, as is China and Vietnam (Mishra 2012, Van Bortel 2008).

Resistance to DDT has significant ramifications, beyond that of reducing the efficacy of DDT treatments. Mutations that result in DDT resistance have also been found to confer cross resistance to other classes of insecticides, such as pyrethroids; a chemical family commonly used in malaria control programs (Bigoga 2012). Additionally, it has been suggested that a malaria outbreak in South Africa was linked with the migration of insecticide resistant mosquitoes from Mozambique (Denholm 2002). Given the potential ramifications to public health, there is a particular need to understand the genetic and biological changes that result in this phenotype.

Drosophila as a model for studying insecticide resistance

Insecticide resistance arises out of a change in the genetic code of an organism. This mutation will likely have one of two primary effects: It may alter the target site within the organism, or it may impact the metabolism of the organism, increasing its ability to detoxify the molecule (Daborn 2002). Research into resistance-conferring mutations has yielded valuable knowledge on the toxic mechanism of insecticides, as well as insight into how toxins are disarmed by insects before reaching the target site. Such knowledge has led to more prudent uses of insecticides and guided development of next generation insecticide compounds (Perry 2011, Rex Consortium 2013). Therefore, elucidating the molecular basis of insecticide resistance is essential, and will continue to enhance and inform future pest control activities.

Many of the processes involved in insecticide resistance are highly conserved, and therefore, insight into resistance is often transferable between insect species (Perry 2011, McKenzie 1994). In fact, the model species *Drosophila melanogaster* has historically been used to research this topic. The ease of lab culture, and the wide array of genetic and molecular tools developed over the past century make *Drosophila* an ideal system to study insecticide resistance further. The availability of the complete genome sequence, in conjunction with the ability to precisely alter the genome, provides an opportunity to understand the underlying mechanisms of insecticide resistance and illuminate the development of resistance mutations.

Previously, a lack of knowledge in this area prevented the anticipation of resistance mechanisms. Classic insecticides were once developed and used without an understanding of their toxic mechanism or the metabolic systems that may render them non-toxic (Perry 2011, Rex Consortium 2013). Moving forward, a comprehensive understanding of these systems will help in the struggle to control agricultural pests and disease vectors.

DDT resistance in wild populations of *Drosophila*

Transposable elements can be a powerful adaptive force, and have driven the rapid evolution of many phenotypes. Their persistence in nearly all in sequenced genomes to date suggests that they have significant influence in the evolutionary path of many species. In humans, surveys of regulatory regions have revealed that between 20-25 percent of these regions are transposon-derived sequences (Jordan 2003, Lowe 2012). There is additional evidence that transposable elements have made important contributions to functional coding sequences in humans (Britten 2006). These data argue in favor of a model where transposable elements are, at times, conferring novel and advantageous changes to genomes; either by contributing new exon sequences, or altering gene expression by transposition.

Nonhuman examples of transposable elements functionally altering the genome are equally persistent (Charlesworth 1994). Previous studies have linked TE insertions to significant population-wide changes in the expression of metabolic and detoxifying enzymes (Schlenke 2004). Under high selective pressures, transposon rearrangements allow for rapid adaptation. For this reason, insecticide resistance is particularly

interesting to many studying the field of evolution given the rapid rise of insecticide resistance mutations (Denholm 2002) and that the selective agent is known.

One such instance is that of DDT^r in *Drosophila melanogaster*; an allele conferring resistance to the once widely used insecticide DDT (French-Constant 2006). DDT^r is now known to be caused by the Accord transposon insertion upstream of the Cyp6g1 promoter (Daborn 2002). This mutation is associated with constitutive Cyp6g1 over-expression, a member of the P450 family of enzymes, widely known for their role in detoxification. This site has experienced rapid on-going evolution, with repeated insertions of transposable elements resulting in gene duplications and the addition of 5' regulatory information (Schmidt 2010). These insertions have contributed tissue specific enhancers (Chung 2007), and have therefore not only changed the levels of Cyp6g1, but also its expression pattern. The occurrence of parallel mutations is not uncommon in instances of high selective pressure. Such is the case of the Cyp6g1 gene, where a Doc transposon inserted in the 5' regulatory region of Cyp6g1 is also associated with increased Cyp6g1 expression and insecticide resistance in *Drosophila simulans* (Schlenke 2004). This mutation is of particular interest, because with transposition, the Doc element relocated a region of regulatory sequence from Cyp12c1; raising the possibility that the transposable element has repurposed an existing functional genome sequence. Yet, little is known about this mutation, and it is unclear how the Doc transposon has altered transcription of Cyp6g1. In this study we have characterized the expression pattern of this mutation in larvae and adult flies, and we demonstrate that the region of the Doc insertion directly upstream of the Cyp6g1 promoter contains tissue specific enhancers.

Materials and Methods

Drosophila Strains

All *Drosophila* stocks were maintained at 25° C on standard media with a 12 hour light/dark cycle. *Drosophila simulans* strains Sim6 and Sz3, previously characterized (Schlenke 2004) were used as the Doc-positive and Doc-negative lines respectively. The presence or absence of the Doc insertion was confirmed with PCR, using primers DocF (AGC TGA ATT CTG TTC TAA GTC CAC ATA) and 6g1_09R (ATT AAA GCT CTA CGC ACC GC) (data not shown).

Insecticide Assays

Resistance to DDT was measured for the strains Sim6 (Doc+) and Sz3 (Doc-) by using a contact assay. Glass scintillation vials (20 ml) were coated with 400 μ l of DDT/acetone solution and rolled continuously until acetone had evaporated: Resulting in DDT concentrations per vial of 0 μ g, 1 μ g, 2.5 μ g, 5 μ g, and 10 μ g. For three replicates of each line, 20 female flies, 3-7 days old were placed into the treated scintillation vials; each vial was subsequently plugged with a cotton top that had absorbed 2 ml of 5% sucrose solution. Mortality was measured 18 hours after the initiation of DDT exposure.

Transcript Length

To test for the presence of a new transcriptional start site within the Doc insertion, transcript length of Cyp6g1 was measured in Sim6 (Doc+) and Sz3 (Doc-). Three forward primers were used, with increasing distance from the Cyp6g1 transcription start site. Primer 6g1P_A (AGT GCG GTG CGT AGA GC) is downstream of the wildtype Cyp6g1 transcription start. Primer 6g1P_B (TTG CTT TGG TTT GTT TGT CG) is located within the Cyp6g1 promoter region, but upstream of the wildtype Cyp6g1 transcription start site. The third primer tested, 6g1P_C (CGC TGA TTT AAT CTC TCG CC), is 53 bp into the Doc insertion. All forward primers shared a common reverse primer 6g1CDS_Rp1 (TGG GGT TCT TTC AAG GAC AT). Sim6 (Doc+) genomic DNA, and cDNA from Sim6 (Doc+) and Sz3 (Doc-) were tested with each primer set. PCR products were sequenced to confirm amplification of the target region (data not shown).

Reporter Constructs

Transgenic strains carrying versions of the Cyp6g1 promoter driving eGFP expression were generated from the Sim6 (Doc+) strain. The reporter construct 6g1P contains only the Cyp6g1 promoter region and was generated with the primers 6g1PromoterF (AGC TGA ATT CCA TTA TAA TAA ATG TAA) and 6g1PromoterR (ACG TGG ATC CGA TTT GAA ATG TTG TT). The reporter construct Doc+6g1P consists of 298 bp of the Doc insertion as well as the complete Cyp6g1 promoter region, primers used for PCR

amplification were DocF (AGC TGA ATT CTG TTC TAA GTC CAC ATA) and 6g1PromoterR. These regions were cloned into the plasmid pStinger (), which does not have an Hsp70 minimal promoter.

To determine if the Doc insertion by itself is able to drive expression of Cyp6g1 two additional DNA fragments were separately cloned into pRed H-pelican, with Hsp70 minimal promoter. The 298 bp region of Doc directly upstream of the Cyp6g1 promoter was isolated from the Sim6 (Doc+) line, using the primers DocF and DocR (AGC TGG ATC CAT TCT TAG TTT CTC AA), resulting in the reporter construct DocHsp70. A reduced section of the Doc insertion, including the hitch-hiking elements of Cyp12c1, but excluding the Doc transposon segment was isolated with the primers 12c1F (ACG TGA ATT CGT CTA CAC TTG ACA CA) and DocR, and cloned into pRed H-pelican to make construct 12c1Hsp70.

Due to low the transformation rates in injected *D.simulans*, w1118 *D.melanogaster* were transformed with the reporter constructs. Previous work has shown that non-coding regions of closely related drosophila species can have conserved expression patterns when used to transform *D. melanogaster* (nature paper), and therefore such transgenic flies are able to act as valid measures of gene expression.

The expression patterns of multiple lines of transformants were compared for each reporter construct. The Doc+6g1P transgenic line with greatest GFP fluorescence intensity was used for imaging. For comparison of expression pattern, the DocHsp70 line was crossed to the Doc+6g1P line, and their offspring imaged. Tissues were hand dissected for imaging, fixed in 4% paraformaldehyde for 15 minutes. Tissue samples were counter stained with Dapi and mounted in 50% glycerol solution. Digital pictures

were taken with the Olympus DP30BW system, and images were digitally edited with Adobe Photoshop.

Real-time PCR

Midgut, malpighian tubules, and fatbodies were dissected from 40 late 3rd instar larvae, 10 larvae per replicate, for both Sim6 (Doc+) and Sz3 (Doc-). Adult flies 3-7 days old were dissected in identical fashion. Whole body RNA extractions were carried out on similarly aged individuals, 5 intact bodies per replicate. RNA extraction and real-time PCR were performed using standard techniques. Primers used were RP49Fp2 (CCA AGA TCG TGA AGA AGC G) and RP49Rp2 (GTT GGG CAT CAG ATA CTG TC) for control gene *RP49*, and 6g1rtF (GGA TTC GAG ACC TCC TCC TC) and 6g1rtR (CCA AAG CTT CGT TGA TCT CC) for *Cyp6g1*. Analysis of Rt values were calculated using the 2delta-delta-ct method (Livak 2001) and log transformed.

Results

Doc insertion and resistance to DDT

It has been previously shown that *D. simulans* with the DDT^r locus, which confers resistance to DDT, have a Doc transposon insertion directly upstream of the *Cyp6g1* promoter, along with two hitch-hiking gene elements (Figure 1). To confirm that

Sim6(Doc+) maintained this phenotype, insecticide resistance was measured and the LD₅₀ for each strain was calculated using logistic regression (Figure 2). Sim6 had greater resistance to DDT, with a LD₅₀ of 6.77 μ g (+/- 0.40), as compared to the Doc-negative strain Sz3, 2.74 (+/- 0.17).

Cyp6g1 transcript length

To determine if the increase in Cyp6g1 transcript abundance is due to a new transcription start site imported by the Doc insertion, the transcript length of Cyp6g1 in Doc+ and Doc- lines were compared. Only primer pairs located within the predicted Cyp6g1 transcript were able to amplify product (Figure 3), indicating that the Doc+ line does not possess a new transcription start site.

Characterization of Cyp6g1 expression

Expression of GFP driven by constructs Cyp6g1P and Doc+6g1P (Figure 4 A-B) was examined to determine possible difference in tissue specific expression. In strains driving GFP expression under control of the Cyp6g1 promoter only (transgenic strain 6g1P) fluorescence was seen in the fatbody and malphigian tubules of third instar larvae. No detectable levels of GFP were observed in the midgut (Figure 5 D-F). Adults of the 6g1P lines showed similar expression patterns, driving GFP in the malphigian tubules and no observable expression in the midgut (Figure 6 C-D). GFP expression in adult fatbody was not detectable in any line due to autofluorescence. Differences in expression

pattern were seen when compared to Doc+6g1P transgenic line; GFP was observed in the fatbody, malphigian tubules, and midgut of third instar larvae (Figure 5 A-C). Similarly, noticeable expression was also seen in the adult midgut and malphigian tubules of the Doc spanning line (Figure 6 A-B).

To quantify possible tissue specific differences observed in the transgenic lines, semi-quantitative RT-PCR was performed on the *Drosophila simulans* Sim6(Doc+) and Sz3(Doc-) lines. Tissues dissected for semi-quantitative RT-PCR were selected based upon the expression pattern observed in the transgenic lines. Cyp6g1 transcript levels were elevated in the Sim6(Doc+) larvae. The fold expression change values have been normalized to Sz3 expression: whole larvae (3.4, $p=0.028$), fatbody (2.9, $p=0.028$), malphigian tubules (4.3, $p=0.028$), and midgut (1.8, $p=0.057$) (Figure 7). Adult expression of Cyp6g1 revealed a pattern similar to that seen in the transgenic constructs, and adult fatbody was revealed to have no expression change: whole body (8.9, $p=0.028$), fatbody (1.0, $p=1$), malphigian tubules (21.8, $p=0.028$), and midgut (18.6, $p=0.057$) (Figure 8). Some of the p-values generated using the Wilcoxon-mann test are non-significant due to variation within replicates, although a trend of higher expression in these tissues is observed. Relative abundance of Cyp6g1 transcript was also calculated, and yielded similar results; with greater transcript abundance both in Sim6(Doc+) larvae and adults (Table 1).

Tissue specific enhancers within Doc insertion

The differences in expression pattern between the full-length promoter constructs, suggested further characterization of the Doc region itself may be insightful.

Specifically, we were interested to see if the Doc and hitchhiking region contained tissue specific enhancers that could drive expression in the absence of the Cyp6g1 promoter.

To test this, two additional constructs were made, containing regions of the Doc element and accompanied by a minimal promoter (Figure 4 C-D). The subset of the Doc region, Cyp12c1 hitch-hiking element, did not drive RFP expression in any line (data not shown). It appears that this region is not enough to drive expression on its own; nevertheless, the larger Doc segment did drive RFP expression. Flies of the DocHsp70 line were crossed to the Doc+6g1P line to view expression overlap. 3rd instar larvae from the resulting cross were examined for fluorescence. The DocHsp70 line expressed RFP in the fatbody, malphigian tubule, and midgut (Figure 9), although some cells in the tissues expressed a mosaic pattern of GFP or RFP expression. Adult expression of RFP driven by the Doc construct was visualized in the midgut and malphigian tubules (Figure 10). Again, mosaic pattern was observed between cells within the malphigian tubules.

Discussion

In this study, we have demonstrated that the insertion of the Doc transposon, upstream of the Cyp6g1 promoter increases Cyp6g1 transcript abundance in a tissue specific manner. Additionally, it has been shown that this elevation in Cyp6g1 transcript is not a result of

an altered transcription start site. In fact, it appears that transposition of the Doc element has imported enhancers within the transposon sequence that are driving this change in expression pattern, and that the hitchhiking gene of Cyp12c1 is not solely responsible for the observed changes. However, It is unclear how the inserted sequence is interacting with the endogenous promoter and enhancer regions. Future study into this area may yield important information regarding the evolution of the genome and novel gene adaptations.

Previous studies examining the mutations conferring insecticide resistance have tended to focus exclusively on one developmental stage. Here we have shown that the Doc insertion alters adult and larval expression patterns differently. Although the specific mechanism responsible for differential expression at various developmental stages is unknown, it is possible that this represents life-stage specific selection pressures.

It has been proposed that enhancers within the transposons sequence regulate TE expression in a temporal and tissue-specific manor (Faunes 2011, Tomancak 2002). Yet, that this insertion has resulted in such an important physiological advantage and resulting population wide change (Schlenke 2004) is remarkable. Mutations conferring insecticide resistance have been of concern to those in the field of public health and evolution alike: Questions as to how they have developed and fixed in populations so quickly have persisted. This study offers a description of how one such phenotype is conferred, and many offer further insight into the evolution of the genome.

This study along with others, have begun to more fully illuminate the plasticity of the genome: It is clear that with the proper impetus, the genome can be quite dynamic, and these changes result in significant modifications of the organism. Mutations are no

longer thought of as restricted to single changes in nucleotides, but rather can be a result of the reshuffling of genomic and non-native DNA.

Our understanding of an adaptive genome is especially pertinent to the topic of insecticide resistance, where strong selective pressures are driving the rapid evolution of these phenotypes. An understanding of how such mutations arise will provide knowledge to guide the future use and development of insecticides.

Previously, insecticides were developed without an understanding of their toxic mechanism. Insecticides were used widely, that had no clear molecular target: However, given the unanticipated speed at which insecticide resistance has evolved and spread, research is beginning to shift into these formerly unexplored areas. Efforts are being made to classify the mode of action of in-use pesticides, and looking forward, some industries are screening chemical compounds to develop insecticides which act on specific targets (Perry 2011). By directly targeting essential genes of the insect, the ability of the insect to adapt may be restricted; as essential genes may be less able to tolerate rapid changes.

Resistance to dieldrin is a classic example of this phenomenon. A resistance to dieldrin (Rdl) allele was identified in the early 1990's as a mutation in a GABA gated chloride channel. The resistance phenotype was later traced to a single amino acid change that resulted in a reduced binding affinity of dieldrin (French-Constant 1994). Interestingly, this mutation is one of only two substitutions that can be tolerated in the protein (Perry 2011). It has therefore been suggested that targeting chemical compounds to areas that cannot undergo amino acid substitutions without substantial fitness costs may hinder the evolution of target-site mutations. However, such a strategy requires

both an exquisite understanding of the insect biology, as well as a concerted effort to target compounds to the essential regions, once they have been identified. Projects of this nature are costly and time consuming; and while advocated by some (Perry 2011), such strategies remain contentious for practicality reasons. Yet, this emphasizes the value of fundamental research of insect biology and resistance mechanisms.

Modifications of the target-site are only one half of the insecticide resistance story. In this study we have characterized a change in the expression pattern of Cyp6g1, which is conferring insecticide resistance through detoxification mechanisms. Although Cyp6g1 has long been identified as a mechanism of DDT resistance (Daborn 2002), its metabolic action remains undescribed. It is clear that a more thorough understanding of insect metabolism would provide valuable insight into the topic of insecticide resistance. Currently, metabolic enzymes in insect species are some of the most rapidly evolving sets of genes (Daborn 2012). This observation highlights their plasticity, and the important role they play in adaptation, despite this, they remain poorly understood as a whole.

The steady rise in insecticide resistance has resulted in calls for “sustainable rational insect pest control” (Perry 2011). A prudent usage of insecticides must be guided by an understanding of insecticide resistance and insecticide mode-of-action. Such knowledge will facilitate monitoring of resistance in wild populations, and may allow for future insecticides to be targeted to regions less prone to mutation.

In this study, we have described the evolution of a single cytochrome-P450 gene: Where by the transposition of DNA into the 5' regulatory region of Cyp6g1 has resulted in population-wide resistance to DDT. Although this study provides a single example of this type of evolution, it contributes to the collective insight into the evolution of

insecticide resistance, and may spurn future research into the action of non-native enhancers within the genome.

Figures

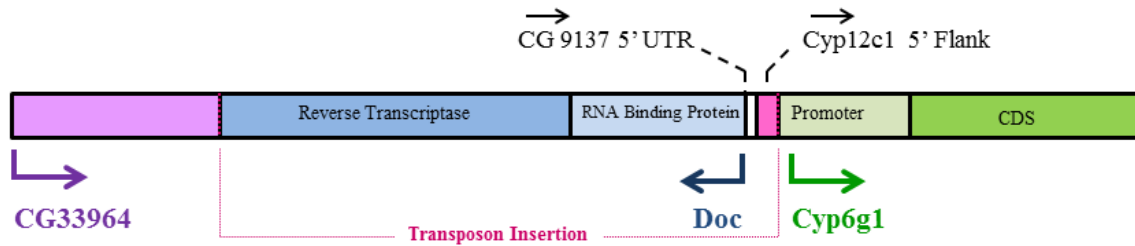

Figure 1. Location of the Doc transposon insertion in DDT-resistant *D. simulans*.

The Doc transposon, along with the hitchhiking gene segments from CG9137 and Cyp12c1, has been located directly upstream of the Cyp6g1 promoter in wild caught DDT-resistant *D. simulans*. Horizontal arrows indicate direction of transcription.

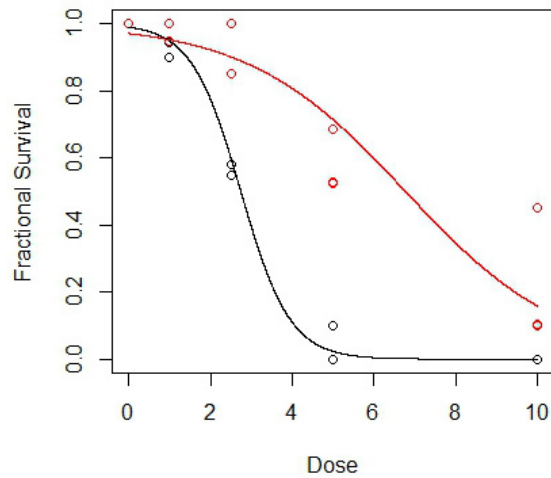

Figure 2. Fractional Survival of adult Sim6(Doc+) and Sz3(Doc-) across DDT concentrations. Mortality data was collected following 18 hours of exposure. Logistic curves were fitted to the data points (Sim6:Red, Sz3:Black). The LD₅₀ for each strain was calculated: Sim6(Doc+) 6.77 μ g (+/- 0.40) Sz3(Doc-) 2.74 μ g (+/- 0.17).

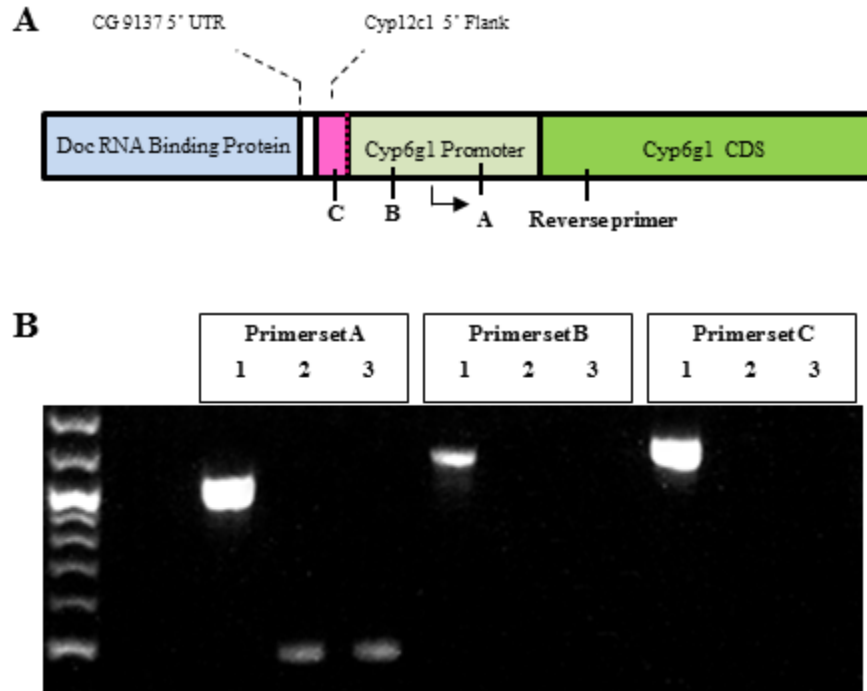

Figure 3. Transcript length of *Cyp6g1* in *Sim6* (Doc+) and *Sz3* (Doc-). Transcript length of *Cyp6g1* was measured using three forward primers A-C, matched to a common reverse primer. (A) The location of primers are marked with lines, arrow indicates the transcriptional start site in wildtype *D. simulans*. (B) Primer sets A-C were tested with each of three samples labeled by numbers 1-3; Doc+ genomic DNA (1), Doc+ cDNA (2), Doc- cDNA (3). All primer sets amplified Doc+ genomic DNA, but only primer set A had PCR product from either cDNA sample.

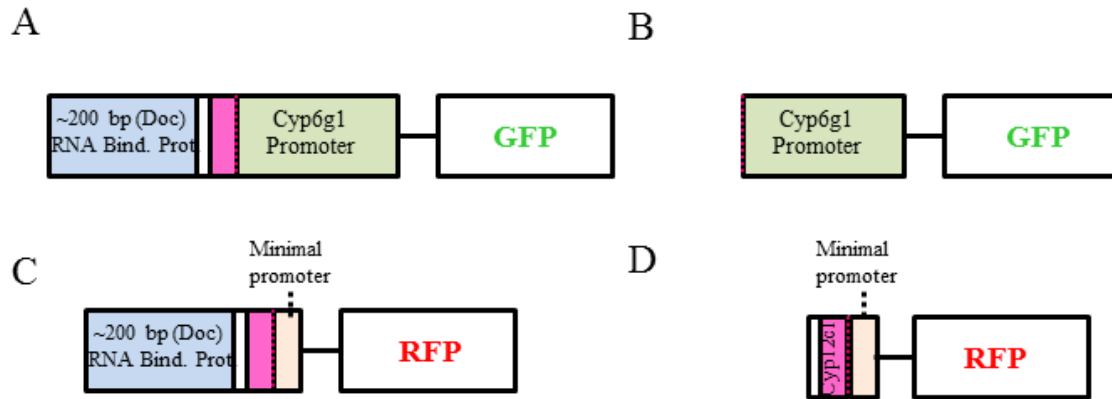

Figure 4. Reporter constructs for characterization of Cyp6g1 expression.

A, Construct Doc+6g1P including 200bp of the Doc insertion, both hitchhiking elements, and the full length Cyp6g1 promoter driving eGFP expression. B, Construct 6g1P, the Cyp6g1 promoter driving eGFP expression. C, Construct DocHsp70, the upstream region of the Doc transposon insertion accompanied by a minimal promoter, driving RFP. D, construct 12c1Hsp70, hitchhiking elements, without the upstream transposon, accompanied by a minimal promoter, driving RFP.

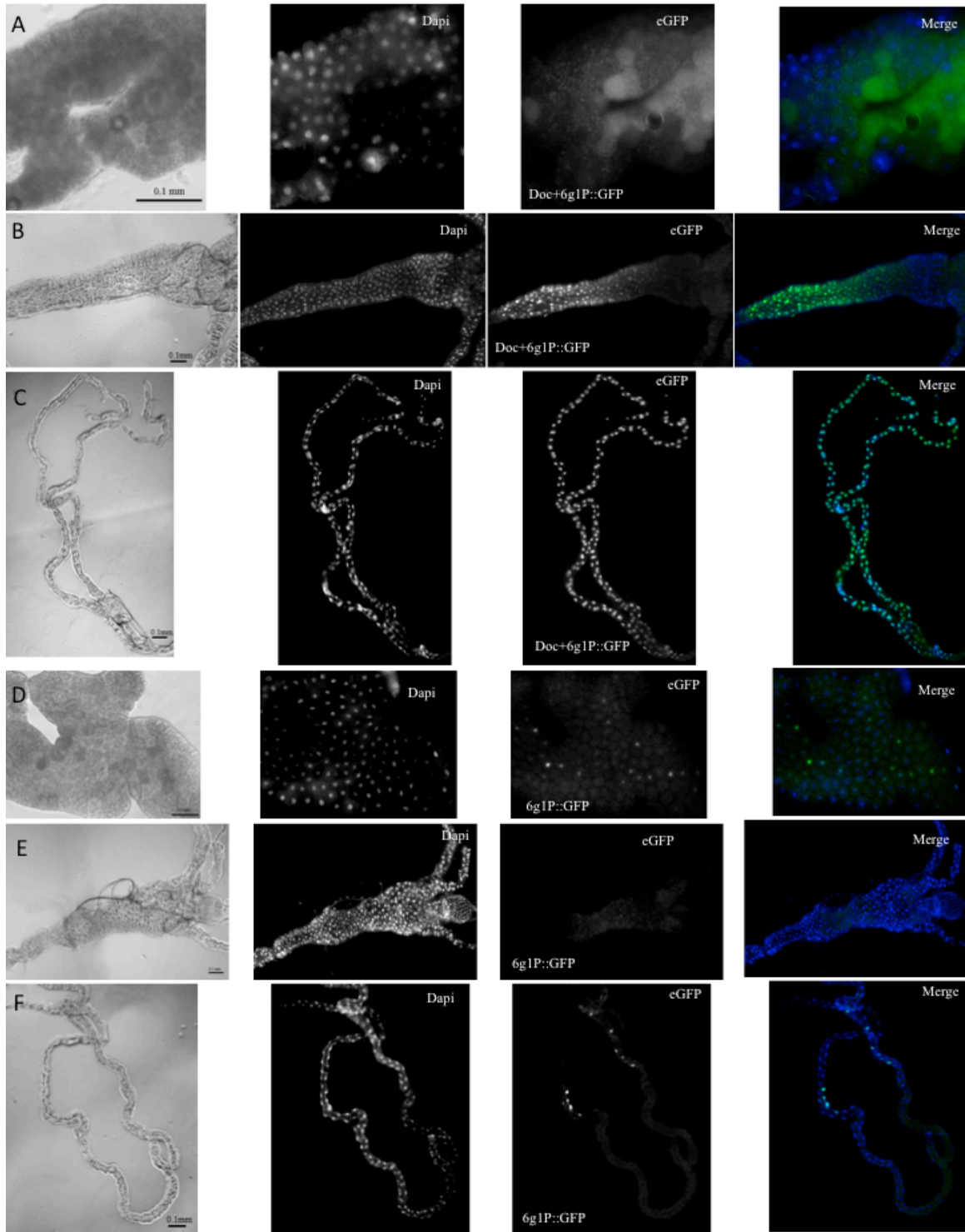

Figure 5. Tissue specific expression of reporter driven by 6g1 promoter and Doc+6g1 promoter in 3rd instar larvae. GFP expression observed in the mid-gut (B, E), fatbody (A, D), and malpighian tubules (C, F).

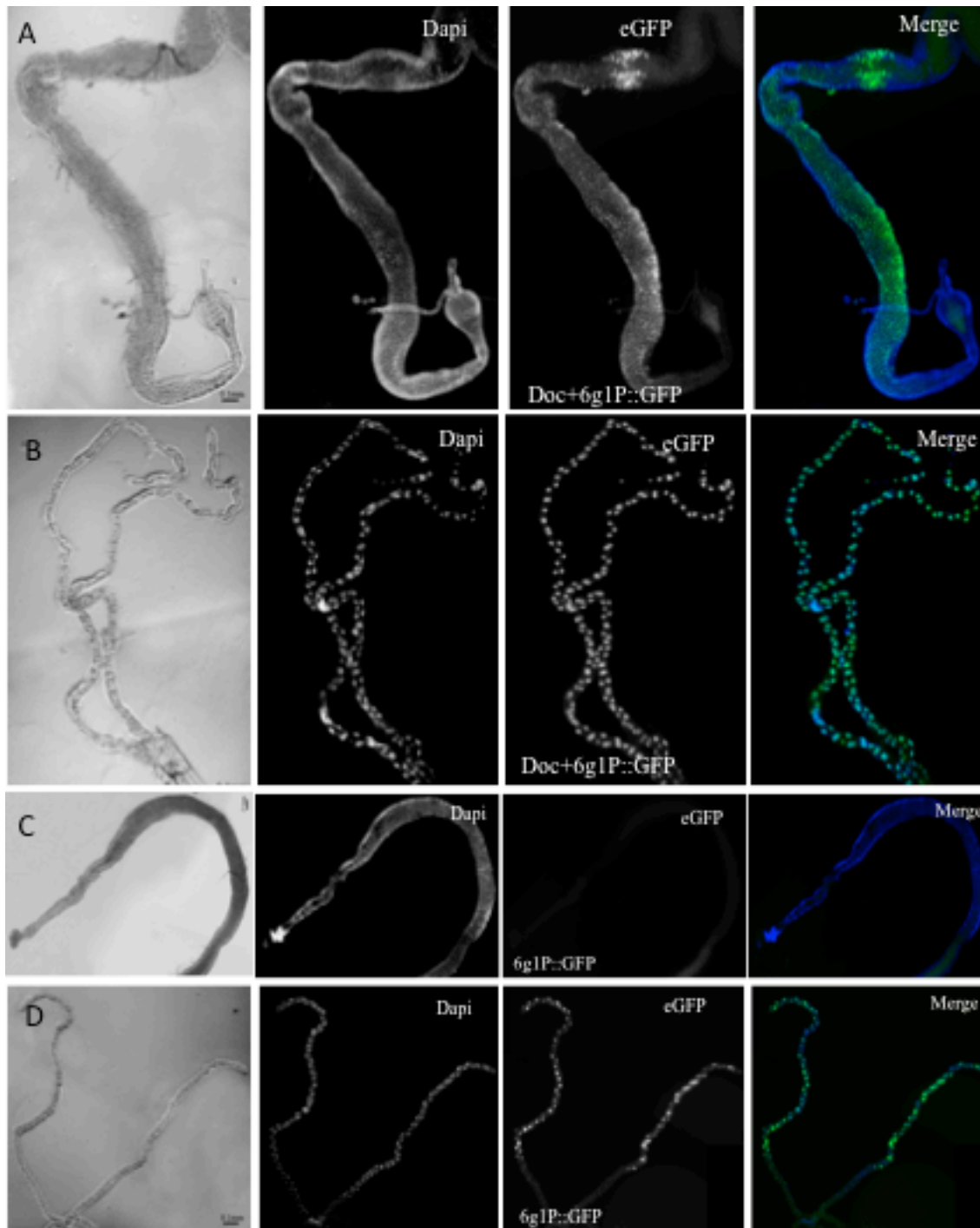

Figure 6. Tissue specific expression of reporter driven by 6g1 promoter and Doc+6g1 promoter in adult transgenics. GFP expression in adult tissues; mid-gut (A, C) and malpighian tubules (B, D).

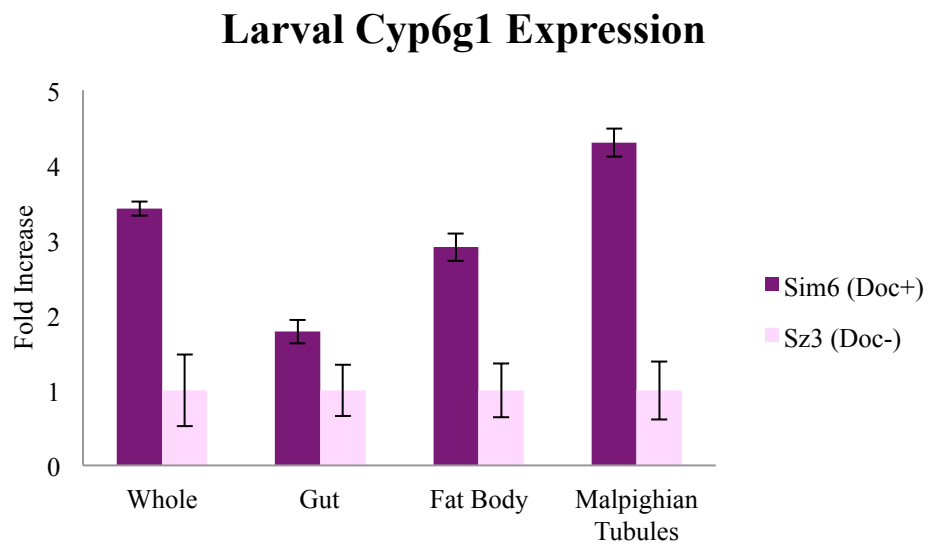

Figure 7. Tissue specific expression of Cyp6g1 in Sim6 (Doc+) and Sz3 (Doc-) 3rd instar larvae. Error bars indicate standard error of replicates.

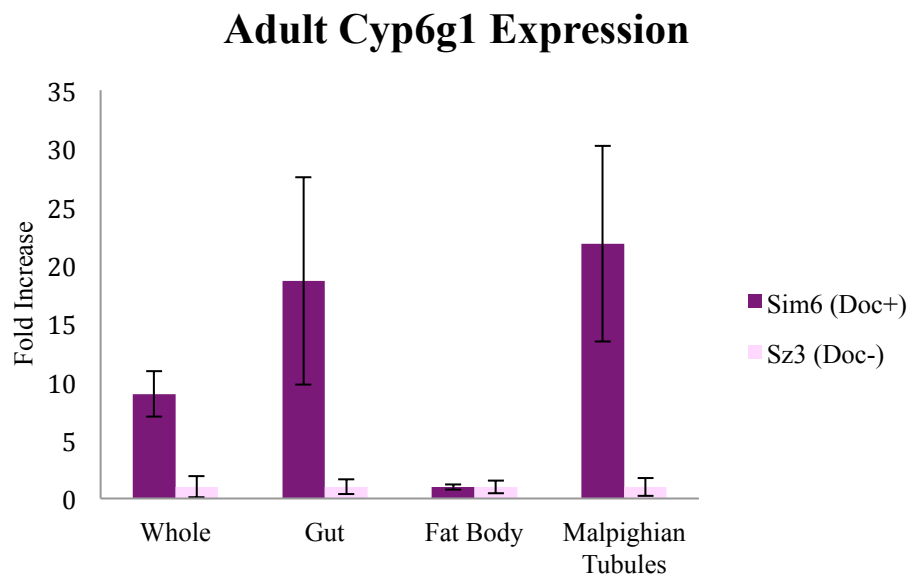

Figure 8. Tissue specific expression of Cyp6g1 in Sim6 (Doc+) and Sz3 (Doc-) adults. Error bars indicate standard error of replicates.

	Whole Body		Gut		Fat Body		Malpighian Tubules	
Larvae								
Sim6 (Doc+)	-2.13	+/- 0.19	-5.36	+/- 0.91	-2.35	+/- 0.37	1.44	+/- 0.12
Sz3 (Doc-)	-6.37	+/- 0.88	-9.95	+/- 2.00	-6.24	+/- 0.73	-0.76	+/- 0.25
Adult								
Sim6 (Doc+)	-3.16	+/- 0.74	-0.24	+/- 1.80	0.10	+/- 1.52	3.99	+/- 1.92
Sz3 (Doc-)	-6.20	+/- 0.34	-3.83	+/- 0.13	0.21	+/- 3.81	-0.79	+/- 0.17

Table 1. Relative quantification of tissue specific Cyp6g1 expression compared to RP49 in Sim6 (Doc+) and Sz3 (Doc-).

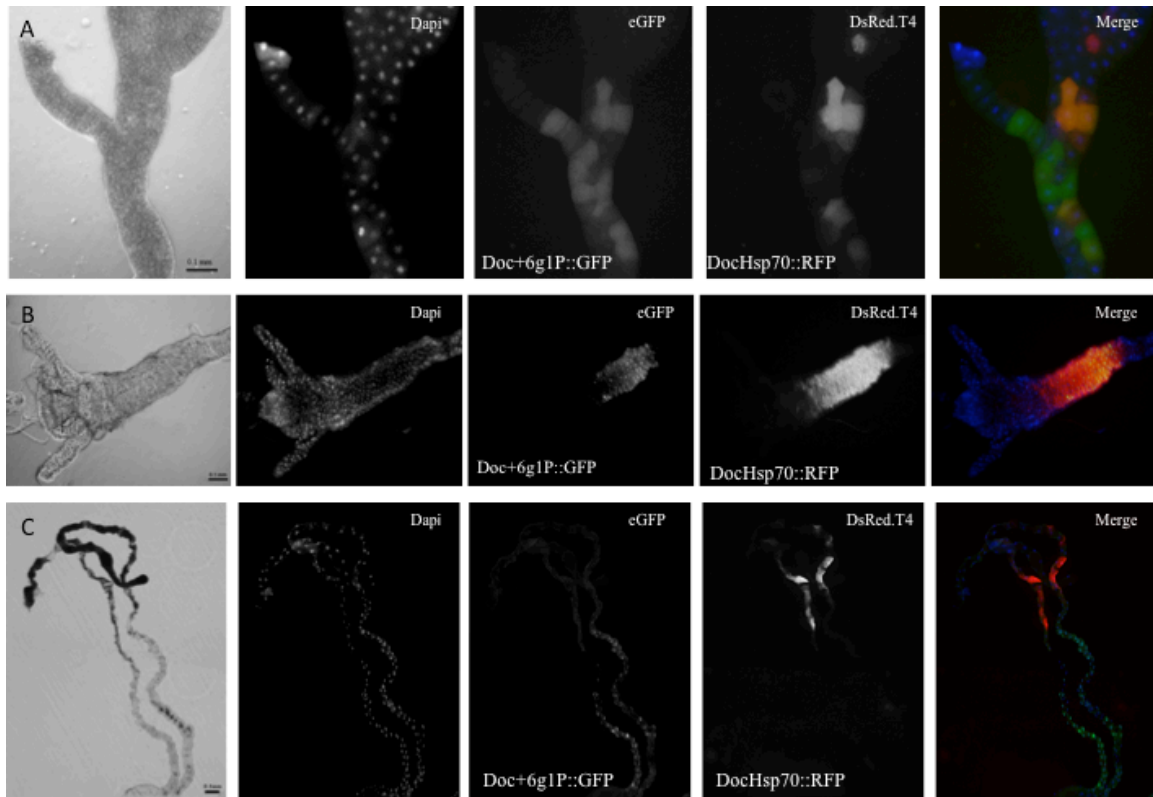

Figure 9. Tissue specific expression of DocHsp70 in 3rd instar larvae. Expression shown in fatbody (A), mid-gut (B), and malpighian tubules (C).

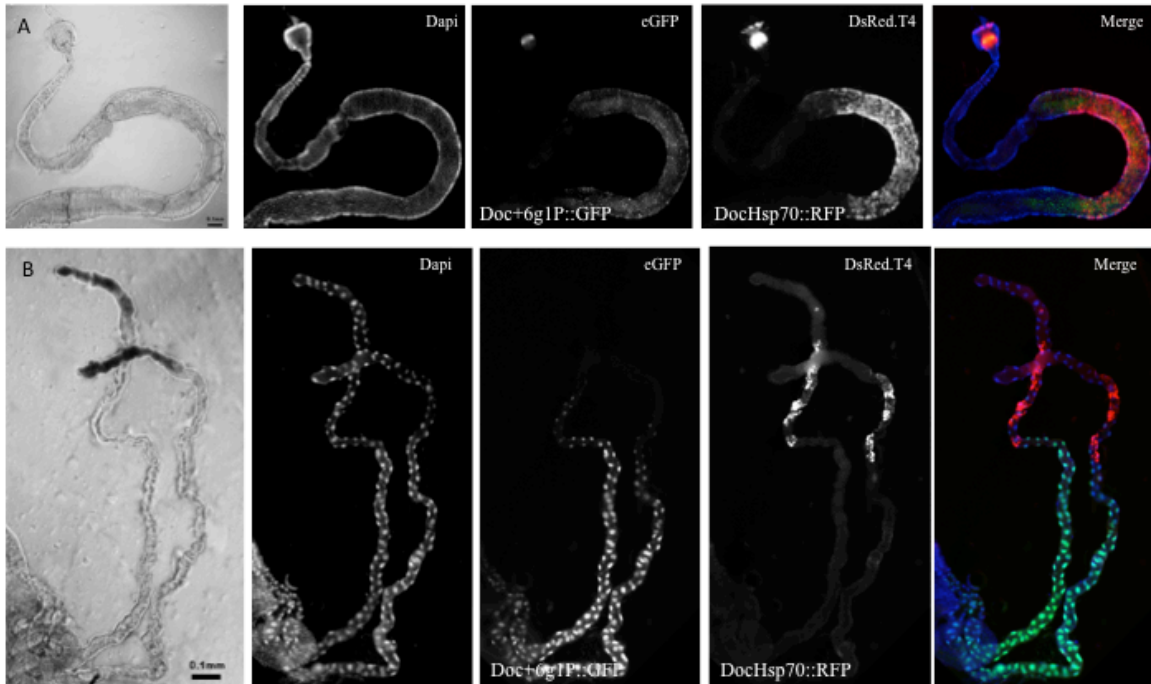

Figure 10. Tissue specific expression driven by DocHsp70 in adults. Expression shown in the midgut (A), and malpighian tubules (B).

References

- Bigoga, J. et.al. Pyrethroid resistance in *Anopheles gambiae* from the rubber cultivated area of Niete, south region of Cameroon. *ACTA Tropica* 124.3, 2012.
- Bridges, D., A. Winters, D. Hamer. Malaria elimination: surveillance and response. *Pathogens and Global Health* 106.4, 2012.
- Britten, R. Transposable elements have contributed to thousands of human proteins. *PNAS* 103.6, 2006.
- Charlesworth, B., P. Sniegowski, W. Stephan. The evolutionary dynamics of repetitive DNA in eukaryotes. *Nature* 371, 1994.
- Chung, H., et. al. Cis-regulatory elements in the Accord retrotransposon result in tissue-specific expression of the *Drosophila melanogaster* insecticide resistance gene *Cyp6g1*. *Genetics* 175, 2007.
- Cohen, J., et. al. Malaria resurgence: a systematic review and assessment of its causes. *Malaria Journal* 11, 2012.
- Daborn, P. et.al. A single P450 allele associated with insecticide resistance in *Drosophila*. *Science* 297, 2002.
- Daborn, P., et al. Using *Drosophila melanogaster* to validate metabolism-based insecticide resistance from insect pests. *Insect Biochemistry and Molecular Biology* 42, 2012
- Denholm I., G. Devine, M. Williamson. Insecticide resistance on the move. *Science* 297, 2002.
- Devos, Y., L. Meihls, J. Kiss, B. Hibbard. Resistance evolution to the first generation of genetically modified Diabrotica-active Bt-maize events by western corn rootworm: management and monitoring considerations. *Transgenic Research* 22.2, 2013.
- Edi, C., B. Koudou, C. Jones, D. Weetman, H. Ranson. Multiple –insecticide resistance in *Anopheles gambiae* mosquitoes, Southern Cote d'Ivoire. *Emerging Infectious Diseases* 18.9, 2012.
- Faunes, F., et. al. Expression of transposable elements in neural tissues during *Xenopus* development. *PLOS One* 6.7, 2011.
- French-Constant, R. The molecular and population genetics of cyclodiene insecticide resistance. *Insect Biochemistry and Molecular Biology* 24, 1994.

- French-Constant, R., P. Daborn, R. Feyereisen. Resistance and the jumping gene. *BioEssays* 28.1, 2006.
- Jordan, I., I. Rogozin, G. Glazko, E. Koonin. Origin of a substantial fraction of human regulatory sequences from transposable elements. *Trends in Genetics* 19.2, 2003.
- Kuntworbe, N., N. Martini, J. Shaw, R. Al-Kassas. Malaria intervention policies and pharmaceutical nanotechnology as a potential tool for malaria management. *Drug Development Research* 73, 2012.
- Livak K., T. Schmittgen. Analysis of relative gene expression data using real-time quantitative PCR and the $2^{-\Delta\Delta C(T)}$ method. *Methods* 25.4, 2001.
- Lo, A., et al. Prevalence of molecular markers of drug resistance in an area of seasonal malaria chemoprevention in children in Senegal. *Malaria Journal* 12, 2013
- Lowe, C., D. Haussler. 29 Mammalian genomes reveal novel exaptations of mobile elements for likely regulatory functions in the human genome. *PLOS One* 7.8, 2012.
- McKenzie, J., P. Batterham. The genetic, molecular and phenotypic consequences of selection for insecticide resistance. *Trends in Ecology and Evolution* 9.5, 1994.
- Mishra, A., S. Chand, T. Barik, V. Dua, K. Raghavendra. Insecticide resistance status in *Anopheles culicifacies* in Madhya Pradesh, central India. *Journal of Vector Borne Diseases* 49.1, 2012.
- Nwane, P., et. al. Multiple insecticide resistance mechanisms in *Anopheles gambiae* s.l. populations from Cameroon, Central Africa. *Parasites and Vectors* 6, 2013.
- Perry, T., P. Batterham, P. Daborn. The biology of insecticidal activity and resistance. *Insect Biochemistry and Molecular Biology* 41.7, 2011.
- REX Consortium. Heterogeneity of selection and the evolution of resistance. *Trends in Ecology and Evolution* 28.2, 2013.
- Schlenke, T.A., D. Begun. Strong selective sweep associated with a transposon insertion in *Drosophila simulans*. *PNAS* 11.6, 2004.
- Schmidt, J., et.al. Copy number variation and transposable elements feature in recent, ongoing adaptation at the *Cyp6g1* locus. *PLOS Genetics* 6.6, 2010.
- Tomancak, P., et. al. Systematic determination of patterns of gene expression during *Drosophila* embryogenesis. *Genome Biology* 3.12, 2002.
- Van Bortel, W. et al. The insecticide resistance status of malaria vectors in the Mekong region. *Malaria Journal* 7, 2008.

Van den Berg, H. et. al. Global trends in the use of insecticides to control vector-borne diseases. *Environmental health perspectives* 120.4, 2012.

WHO. World Malaria Report 2010. World Health Organization: Global Malarial Programme 2010.

WHO. Malaria Fact Sheet N*94. World Health Organization: Media Centre. Revised March 2013

Wyckhuys, K., Y. Lu, H. Morales, L. Vazquez, J. Legaspi, P. Eliopoulos, L. Hernandez. Current status and potential of conservation biological control for agriculture in the developing world. *Biological control* 65.1, 2013.